

MiISO

Exclusive Cable, Premium Performance

User Manual



MQ8

USB Computer Microphone

Package Included:

- USB microphone (4 ft / 1.2 m extension cable)
- Customized packaging box
- MillSO exclusive user guide
- Extra windproof sponge filter muffs

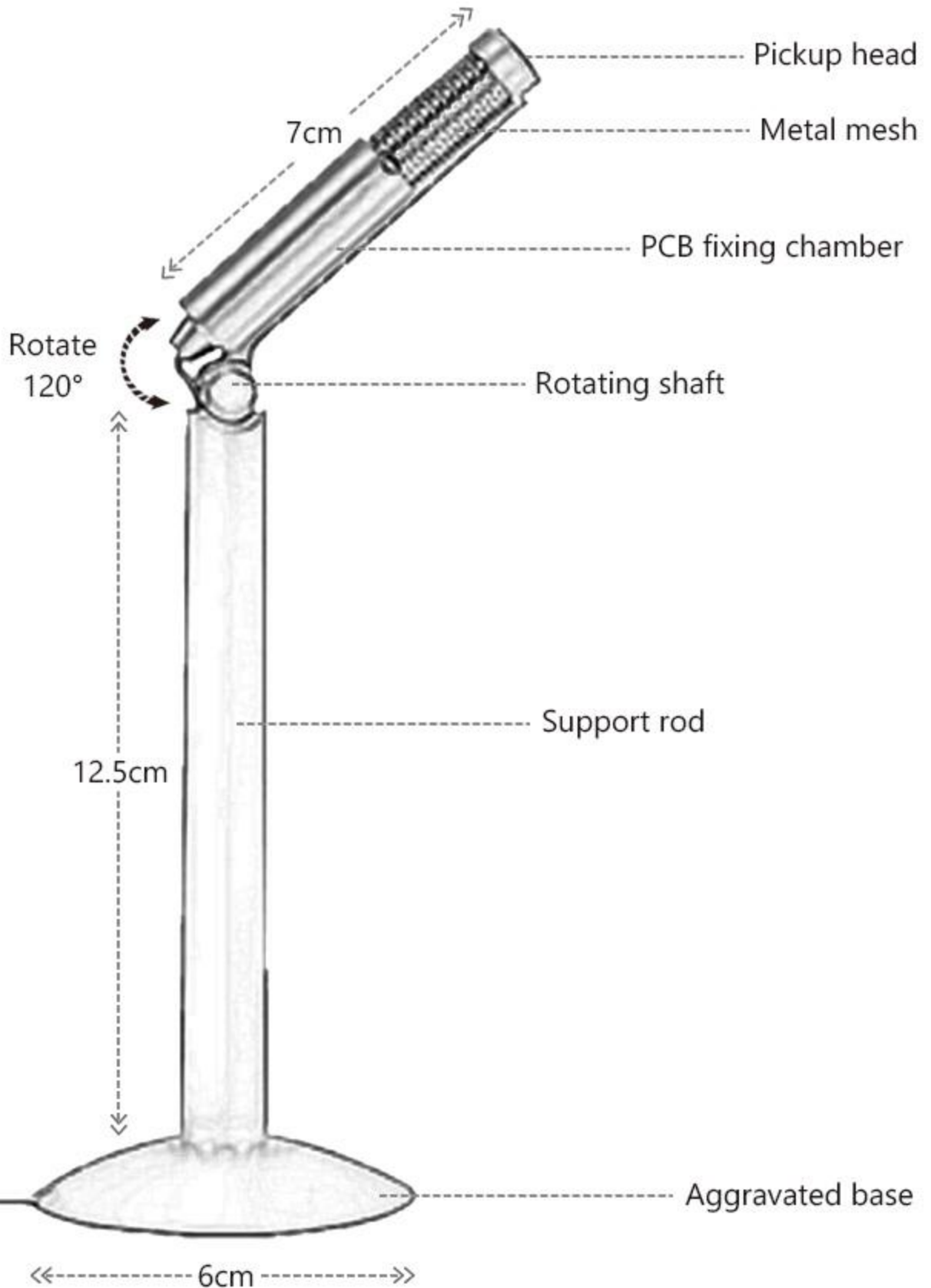

Specifications

Model	MQ8
Directivity	Omni-directional
Connector type	USB-A direct plug
Power supply mode	USB DC4.5-5.0V
Total length	4 Feet / 1.2 M
Frequency response	15Hz-16KHz
Sampling rate	44.1 KHz
Sensitivity	-30±3dB
Impedance	≤ 2.2KΩ

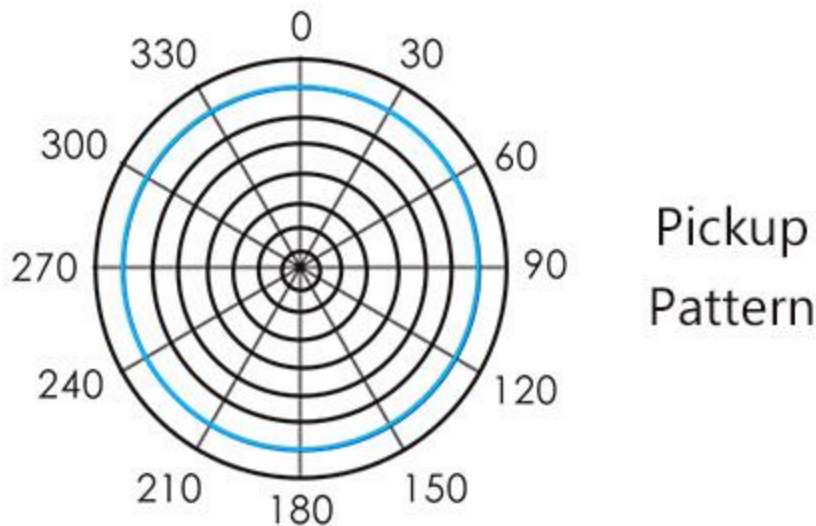

Precautions

Thank you for purchasing the MillISO USB microphone, please read this user manual carefully before use.

1. Can not be used in a humid environment.
2. Can not be used on equipment that exceeds the working voltage of this microphone. The working voltage of this product is 4.5-5V.
3. When it is not used for a long time, please unplug the microphone.
4. When using, do not tap the microphone to avoid damaging the parts.

Using with PC or laptop

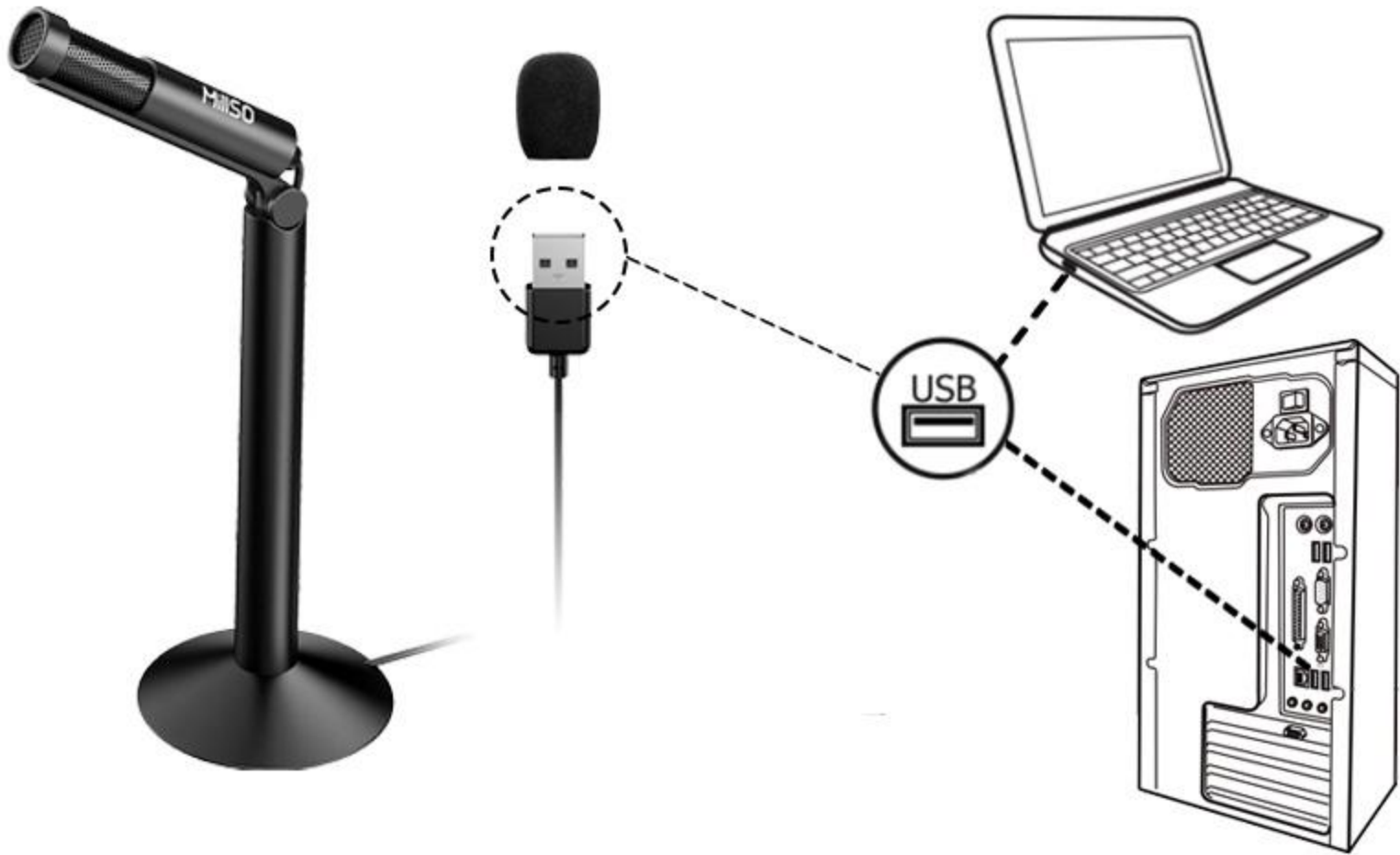

For Windows (Take Windows 10 for example)

To ensure the USB microphone is configured correctly on the PC, follow the steps below:

1. Plug the USB port of the microphone directly into your laptop or desktop computer.
2. Right-click on the sound icon in the system tray and select "**Open Sound Settings**".

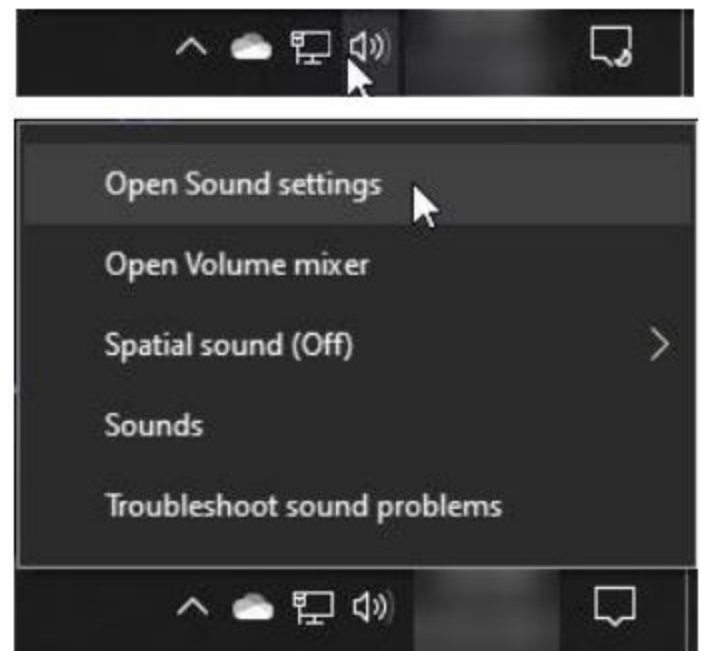

3. Select **Sound Control Panel**

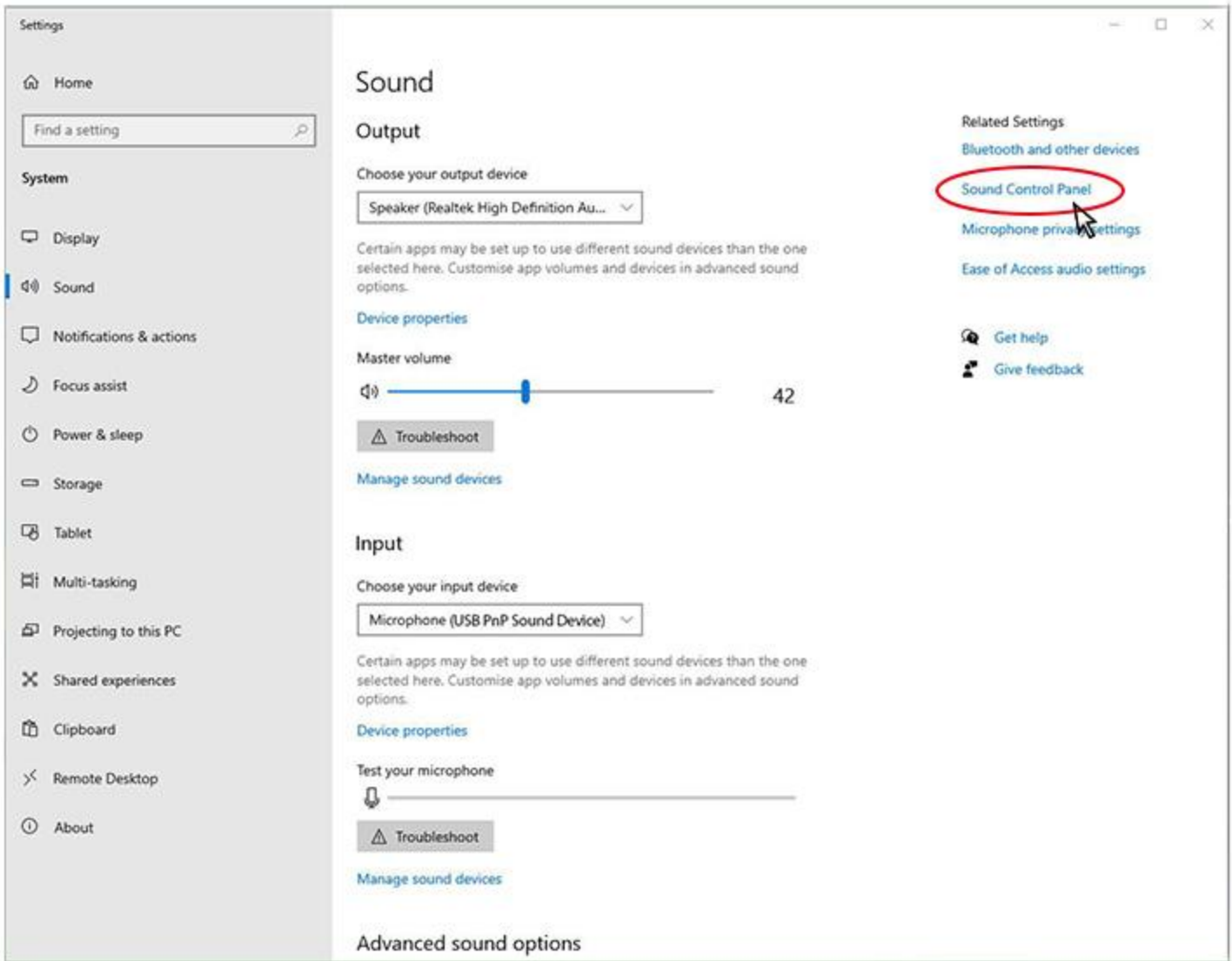

4. On the **Recording** tab, you can see the Microphone icon labeled "**USB PnP Sound Device**" is set up and is on default, double click on microphone, then you can find "**Microphone Properties**".

Notice: If you insert an extra earphone, please make sure the **USB PnP Sound Device** is the default device in the Recording tab.

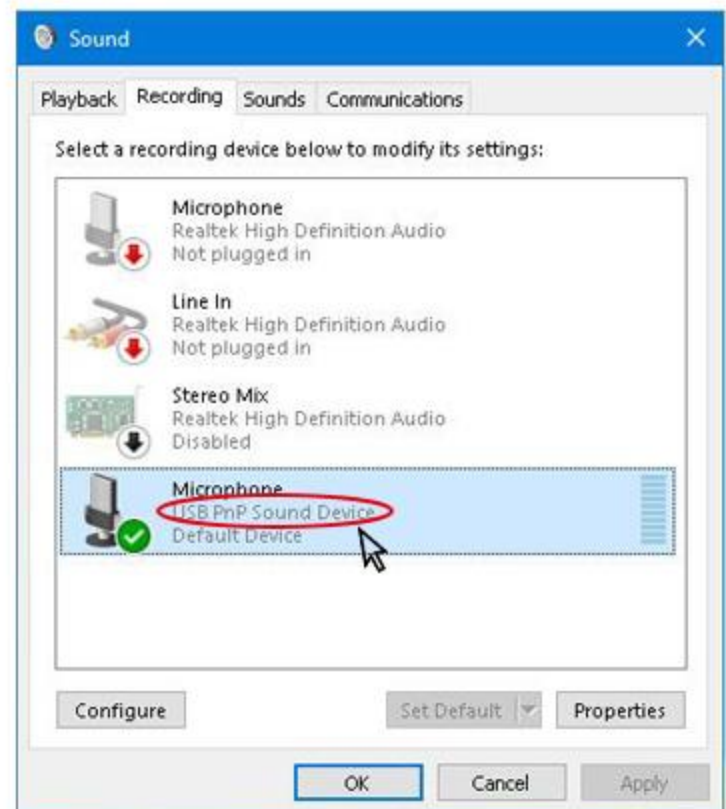

5. On to the **Listen** tab, if you need to monitor when recording, check the "**Listen to this device**" button, then click "**OK**" to save the settings.

Notice: This listen function is for testing the microphone. If you don't need to hear your own voice, please don't turn on the listen function.

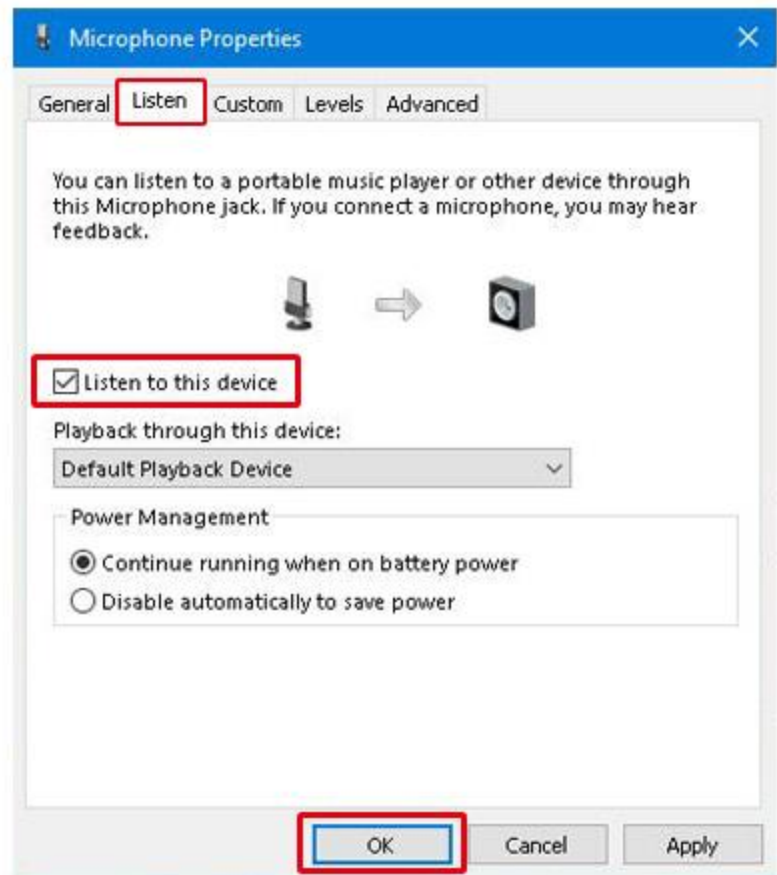

6. On the **Levels** tab, you can adjust the volume according to your personal preference.

Notice: Since each computer system is different, the volume of the microphone needs to be adjusted according to the respective computer.



For Mac OS (Take Macbook Air for example)

To confirm that the USB microphone is configured correctly on Mac, follow the steps below:

1. Click the desktop menu, then click "**System Preferences**"
2. Find "**Sound**" button and click it.

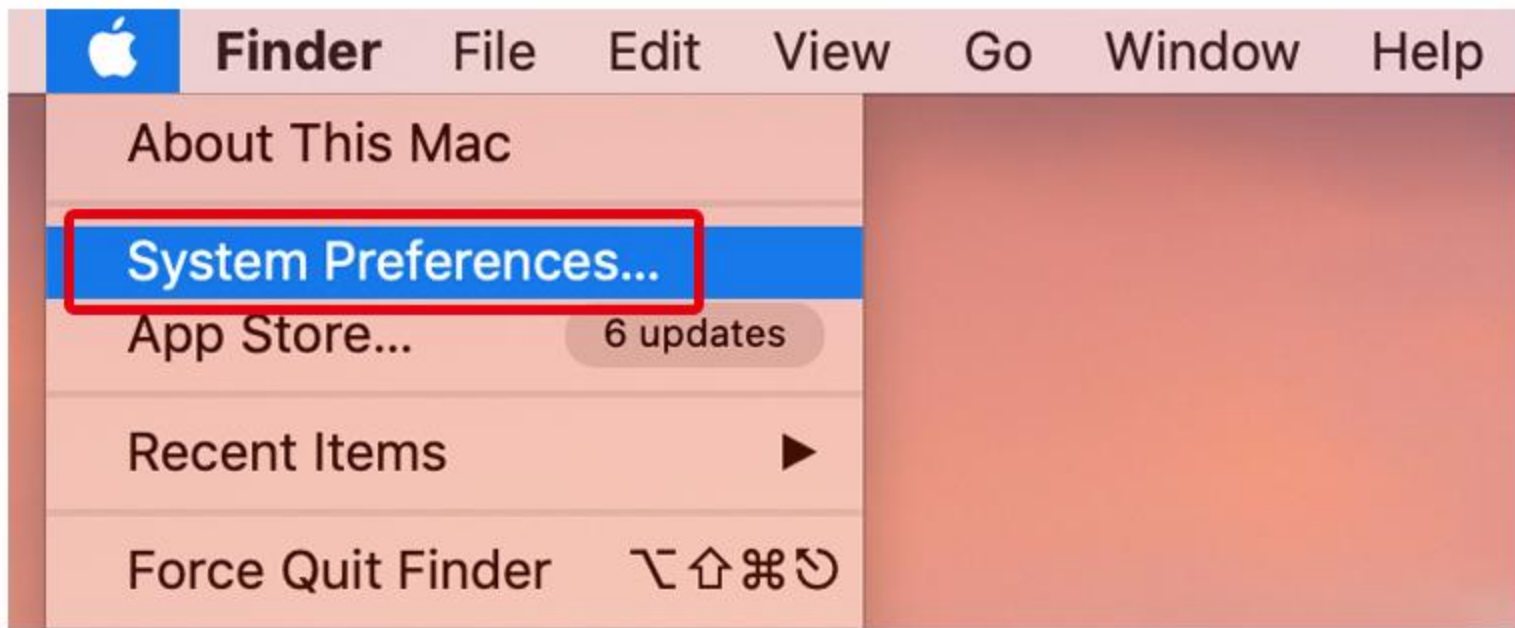

3. Choose input you will find internal microphone (like Macbook Air Microphone), turn off the input volume.

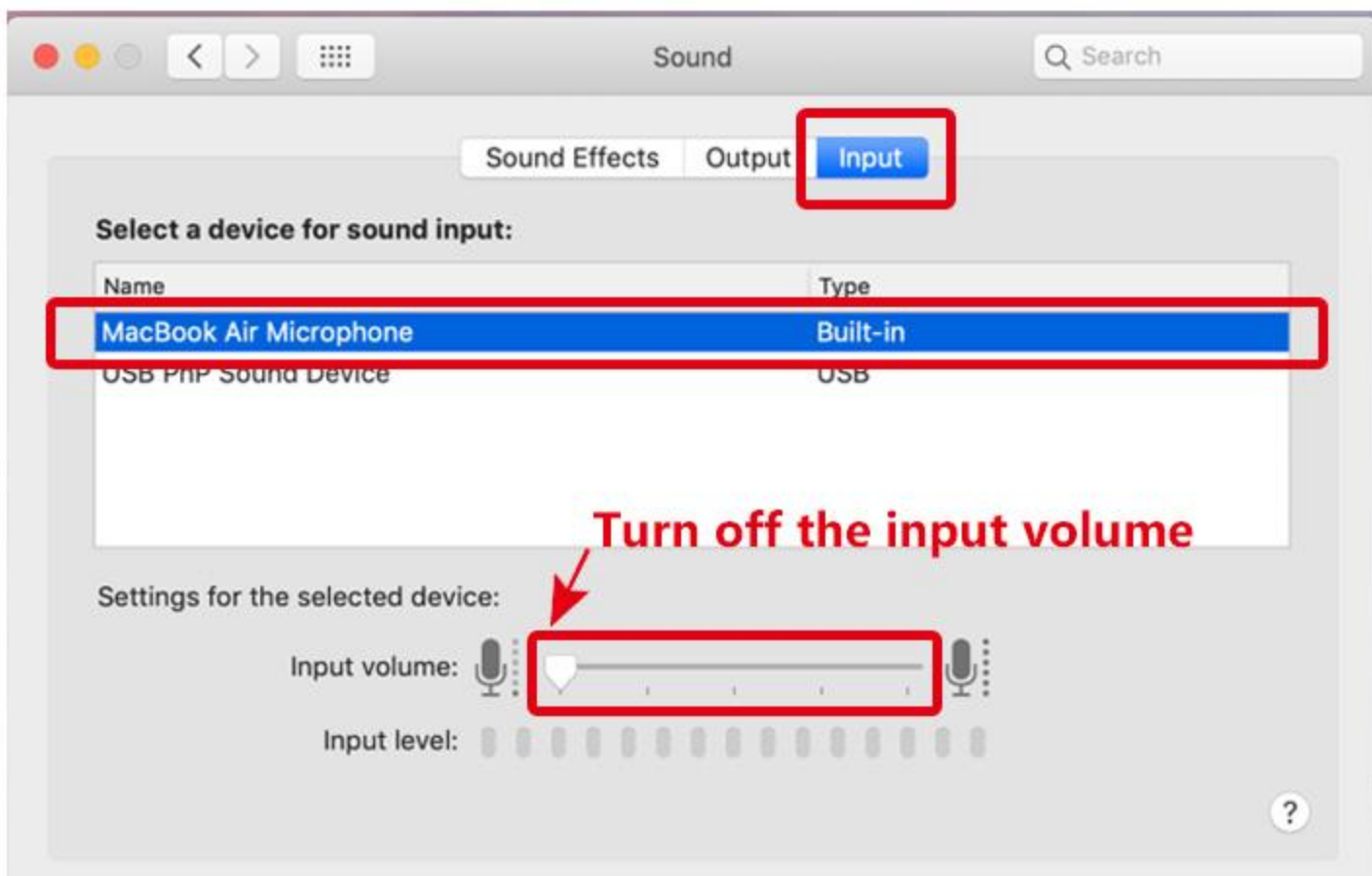

4. Choose "USB PnP Sound Device", and adjust input volume (general adjustment to the middle).

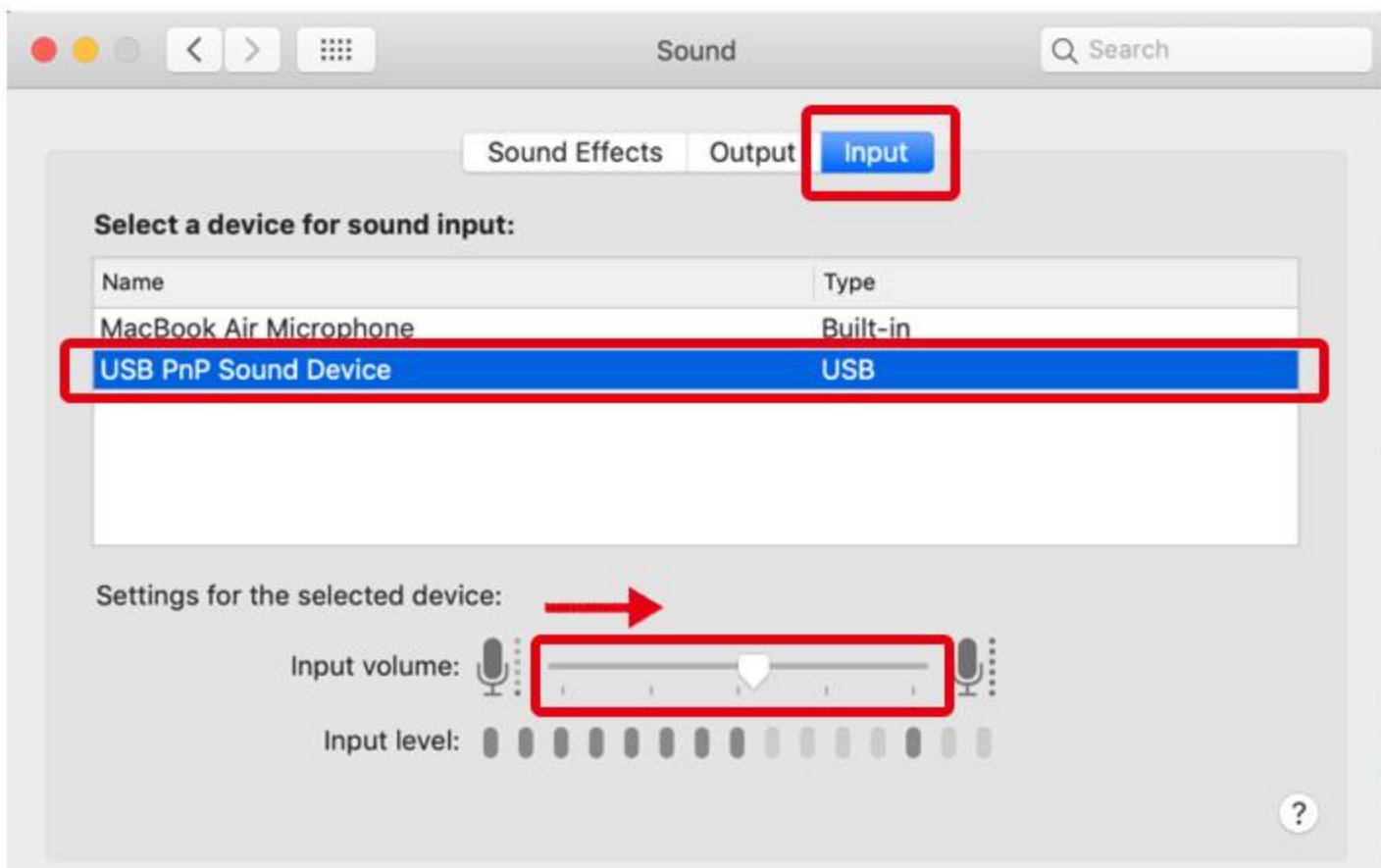

5. Test the microphone sound: search out the computer that comes with the software **"Voice Memos"**

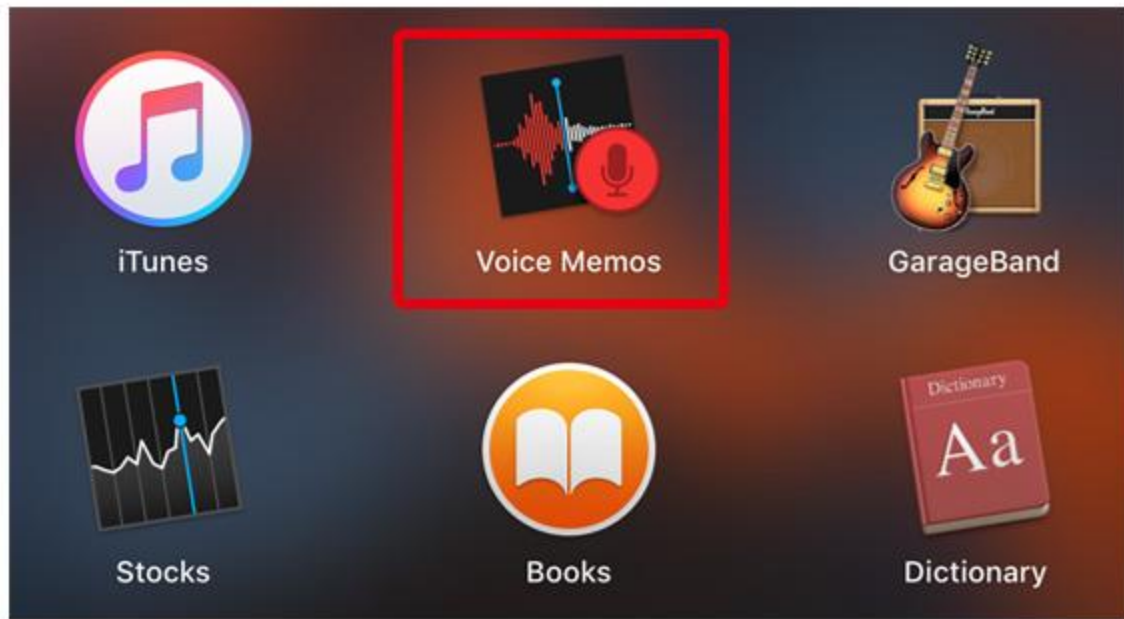

6. After selecting the external USB microphone, click the **Record** button and you can record it.

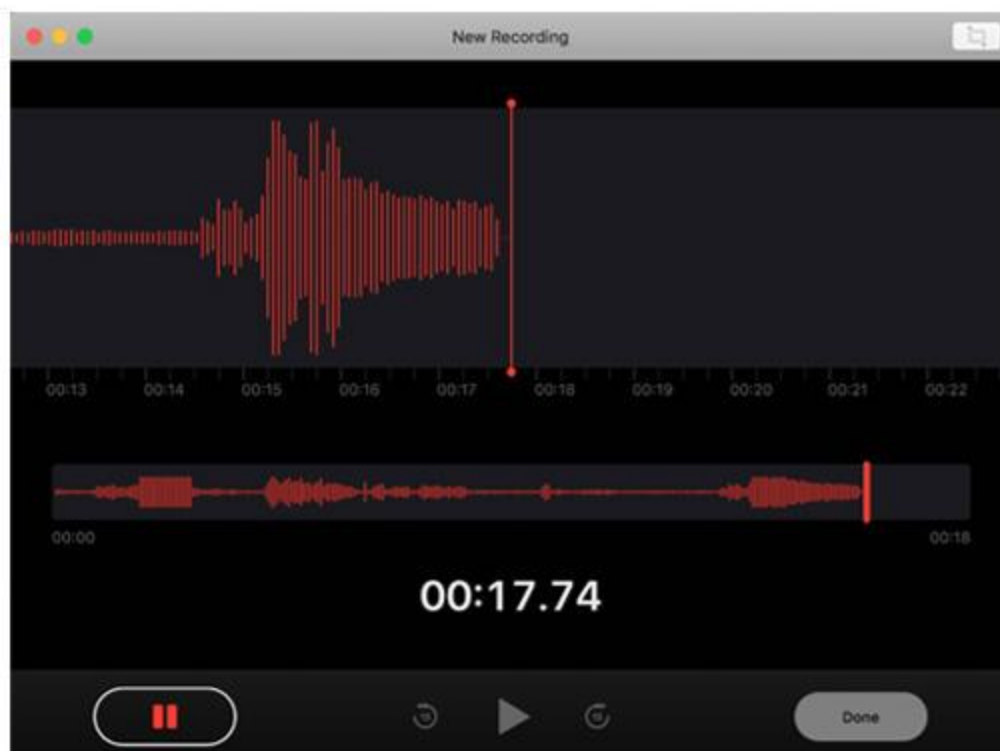
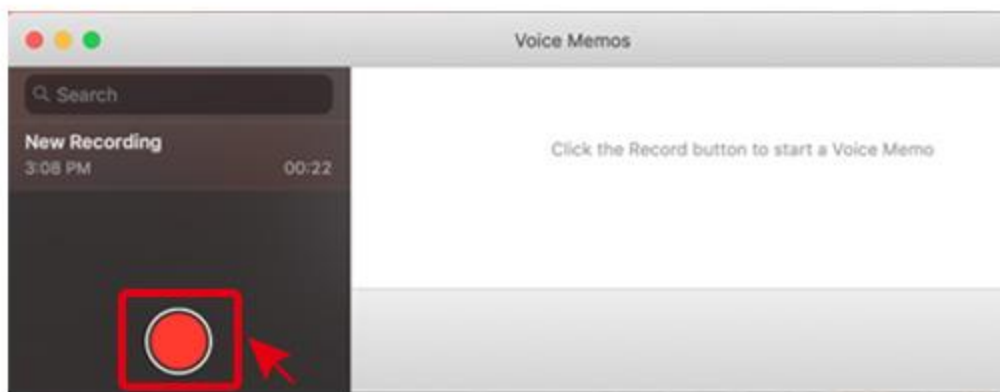

Customer Service

● Warranty Policy

MILLSO offers 24*7 friendly customer service, 18-month extended warranty, and Lifetime Technical Support for our audio adapters, to ensure your pleasing shopping experience.

● Extend to 18-Month Warranty

Email: Edit your order number and "18 months extended warranty"

To: support@millso.com

● Need any help?

Tell your issue to our customer support team via support@millso.com

● Happy with this purchase?

Welcome to share your shopping experience on the product page!

Share with Your Friends



support@millso.com



<https://www.millso.com/>



<https://www.facebook.com/millsofans>



<https://twitter.com/millsofans>